

Request for Proposal (RFP)

For

Beecher Lake Dam Modification

Posting Date:

July 17, 2015



Response Deadline:

August 14, 2015

4:00 p.m. Central Standard Time (CST)

To:

Joseph Siudzinski

Beecher Lake Dam Modification

648 Hoganwood Circle

Sobieski, WI 54171

Table of Contents

I.	BACKGROUND	3
II.	TENTATIVE PROJECT TIMELINE.....	3
III.	RFP DUE DATE	3
IV.	ON-SITE CONTRACTORS MEETING	4
V.	RFP QUESTIONS.....	4
VI.	RFP SUBMISSION REQUIREMENTS	4
VII.	PROPOSAL FORMAT	5
VIII.	SCOPE OF SERVICES.....	5
IX.	CONSTRUCTION SCHEDULE AND CONTINGENCIES.....	5
X.	CONTRACT TERMS.....	6
XI.	REFERENCES	6
XII.	FINANCIAL VERIFICATION.....	6
XIII.	OTHER.....	6
	WORKERS COMPENSATION INSURANCE:.....	7
	AUTO LIABILITY INSURANCE:	7
	GENERAL LIABILITY INSURANCE:.....	7
	ADDITIONAL INSURED.....	7
	SUBCONTRACTOR	7
	WAVIER OF SUBROGATION.....	7
	CANCELLATION NOTICE	7
	PROOF OF INSURANCE.....	7
XIV.	PROJECT CHANGES	8
XV.	ATTACHMENTS	8

I. BACKGROUND

The Beecher and Upper Lakes Public Inland Lake Protection and Rehabilitation District is requesting proposals for the construction of dam modifications to the Beecher Lake Dam located in Sec. 28 T36N R20E, Town of Beecher, Marinette County Wisconsin.

Notwithstanding any other provisions of the RFP, Beecher and Upper Lakes Public Inland Lake Protection and Rehabilitation District reserves the right to reject any or all proposals, to waive any irregularity or informality in a proposal, and to accept or reject any item or a combination of items when doing so would be to the advantage of Beecher and Upper Lakes Public Inland Lake Protection and Rehabilitation District or its taxpayers.

It is further within the right of Beecher and Upper Lakes Public Inland Lake Protection District to reject proposals that do not contain all elements and information requested in this document.

Beecher and Upper Lakes Public Inland Lakes Protection and Rehabilitation District shall not be liable for any losses incurred by the contractor making the proposal throughout this process. The cost of preparing a response to this RFP is not reimbursable in part or in whole to the contractor. Any proposal received will become the property of Beecher and Upper Lakes Public Inland Lake Protection and Rehabilitation District and a matter of public record.

II. TENTATIVE PROJECT TIMELINE

RFP posting	July 17, 2015
On-site contractors meeting 9:00 a.m.	July 27, 2015
RFP questions due by 10:00 a.m.	July 30, 2015
RFP questions answered by 4:00 p.m.	August 4, 2015
RFP proposals due from potential vendors by 4:00 p.m.	August 14, 2015
RFP proposals opened at the Beecher Town Hall at 9:00 am	August 15, 2015

III. RFP DUE DATE

Proposals shall be submitted to the Aquatic Committee Chairperson by no later than **4:00 p.m. central time on Friday, August 14, 2015**. Proposals shall be clearly labeled **Beecher Lake Dam Modification** and submitted to the location/address listed below.

Delivery Address for Hand Delivery, USPS, UPS, DHL, Fed X:

Joseph Siudzinski
Beecher Lake Dam Modification
648 Hoganwood Circle
Sobieski, WI 54171

Each proposal must be received by the due date and time set for this RFP. A proposal received after the established deadline will not be considered.

IV. ON-SITE CONTRACTOR MEETING

An on-site contractors meeting will be held at 9:00 a.m. CST on Monday July 27, 2015 at the Beecher Lake dam. Vendors are not required to attend the contractors meeting to submit a proposal.

V. RFP QUESTIONS

All questions related to this RFP must be submitted not later than 10:00 a.m. CST, July 30, 2015, via e-mail to cdruckrey@marinettecounty.com with “**Questions for Beecher Lake Dam Modification**” clearly in the subject line. Phone call or faxed questions will not be accepted.

Answers to questions will be posted in the form of an addendum to the RFP and placed on the Marinette County website <http://www.marinettecounty.com> on August 4, 2015, not later than 4:00 p.m. CST. It is the responsibility of all interested vendors to access the website for this information. Calls for assistance with the website may be made to (715) 732-7780.

VI. RFP SUBMISSION REQUIREMENTS

The proposal shall be sealed and labeled with the following information:

- Beecher Lake Dam Modification
- Name of Consultant
- Address
- Contact Person
- Telephone and Facsimile Number
- E-mail Address

One original response and two (2) copies are required to be submitted.

The proposal must include the following:

- Statement of Qualifications Attachment A
- Fee Schedule Attachment B
- Reference Sheet Attachment C
- Statement of Understanding Attachment D
- Addendum Sheet, if applicable Attachment E

The vendor shall specify the total cost for the dam modification project.

Upon award of the contract, the selected vendor will be required to submit a federal W-9 Form and payment address to Beecher and Upper Lakes Public Inland Lake Protection and Rehabilitation District.

The proposal shall be prepared with a straightforward, concise delineation of the vendor’s capabilities to satisfy the requirements of this RFP.

A vendor may withdraw or modify its proposal prior to the proposal due date. Any changes or withdrawals must be made in writing prior to the proposal due date.

VII. PROPOSAL FORMAT

Proposals shall be typewritten on standard 8½" x 11" paper. Larger paper is permissible for charts, spreadsheets, or similar documents.

Proposals should be prepared in a simple, cost effective format providing a straightforward concise description of the vendor's capabilities to satisfy the requirements of the RFP. The use of elaborate materials and the inclusion of additional information that has no direct bearing on the project are not desired. Emphasis should be concentrated on accuracy, completeness, and clarity of content. All parts, pages, figures, and tables should be numbered and clearly labeled.

VIII. SCOPE OF SERVICES

Construction of dam modifications to the Beecher Lake Dam located in Sec. 28 T36N R20E, Town of Beecher, Marinette County Wisconsin, and reclamation/stabilization of disturbed areas in accordance with the attached construction plan.

IX. CONSTRUCTION SCHEDULE AND CONTINGENCIES

The Beecher Lake Dam Modification Project is the final part of a three phase project:

Phase I - Successful completion of a partial drawdown of Beecher Lake using siphons. According to WDNR permit the partial drawdown must be completed by October 31, 2015. The Beecher Lake District is responsible for installation and maintenance of the siphons.

Phase II (Beecher Lake Dam Modification RFP) - Installation of a low level drain and valve system through the Beecher Lake dam for the purpose of maintaining the partial drawdown. Dam modification is required to be completed by January 15, 2016.

Phase III (Beecher Lake Channel Dredge RFP) - Construction of a dredged channel between the drain intake structure and the main body of Beecher Lake according to the attached construction plan. Dredging will be let under a separate bid and must be completed during the winter months before ice-out in the spring of 2016.

Construction of the dam modification (phase II) is contingent upon successful completion of phase I, sufficient freezing of the lake bed to support machinery required to complete the dam modification, all WDNR permit approvals to be received by September 1st, and final financial approval by the Beecher Lake Tax District Attendees at the Annual Meeting on September 5, 2015.

Dam Modifications can commence after completion of phase I, as soon as the lake bed is sufficiently frozen to support dam modification equipment. The project must be completed by January 15th, 2016.

If, due to weather or other unforeseen events, phase I of the project cannot be achieved as scheduled, the project will be postponed until the fall and winter of 2016/2017. The total cost quoted by the vendor shall cover the contingency period.

X. CONTRACT TERMS

The vendor may provide a contract to be approved by Beecher and Upper Lakes Public Inland Lakes Protection and Rehabilitation District. If the vendor does not provide a contract, the vendor shall be required to sign a contract similar to Attachment F.

XI. REFERENCES

Each prospective vendor shall provide at least two references and not more than three in which one is required to be in the public sector. References should be based on projects of similar size and scope using the provided Reference Sheet, Attachment C.

XII. FINANCIAL VERIFICATION

Vendor's financial solvency may be verified through financial background checks via Dun & Bradstreet or other means prior to contract award. Beecher and Upper Lakes Public Inland Lake Protection and Rehabilitation District reserves the right to reject Proposals based on information obtained through these background checks.

XIII. OTHER

All work shall conform to all applicable industry standards, federal, state and local laws, codes and ordinances.

No vendor will be provided with financial and/or competitive vendor information on this Proposal until after the award of contract has been made. At that time, all Proposals will be available for review in accordance with the Wisconsin Open Records Law. Beecher and Upper Lakes Public Inland Lake Protection and Rehabilitation District shall not be held liable for any claims arising from disclosure required under the Wisconsin Open Records Law.

Prevailing Wages Standards are applicable to this project and available with bid documents.

Beecher and Upper Lakes Public Inland Lake Protection and Rehabilitation District is exempt from payment of all federal, state and local taxes on its purchases except Wisconsin excise taxes.

Any contract between vendor and Beecher and Upper Lakes Public Inland Lake Protection and Rehabilitation District shall be subject to the laws of the State of Wisconsin. In connection with the performance of work under such contract, the vendor agrees not to discriminate against any employee or applicant for employment because of age, race, religion, color, handicap, sex, physical condition, developmental disability, sexual orientation, or national origin.

By responding to this Proposal, prospective vendors acknowledge and accept the attachments, including insurance requirements and service template contract sample attached.

WORKERS COMPENSATION INSURANCE:

Vendor shall provide statutory workers compensation insurance coverage for its employees who will not be considered employees of Beecher and Upper Lakes Public Inland Lake Protection and Rehabilitation District in any way.

AUTO LIABILITY INSURANCE:

Vendor shall provide a minimum of \$300,000 per occurrence to cover bodily injury and property damage arising out of ownership, maintenance, or use of any motor vehicle, including non-owned and hired.

GENERAL LIABILITY INSURANCE:

Vendor shall provide a minimum limit of \$1,000,000 per occurrence broad form coverage.

ADDITIONAL INSURED

The vendor agrees that all liability coverage policies shall name Beecher and Upper Lakes Public Inland Lake Protection and Rehabilitation District as additional insured with respects to liability arising out of activities performed by or on behalf of the vendor/contractor; products and completed operations of vendor/contractor; premises owned, occupied or used by vendor; or automobiles owned, leased, hired or borrowed by vendor. The coverage shall contain no special limitations on the scope of protection to the Beecher and Upper Lakes Public Inland Lake Protection and Rehabilitation District.

SUBCONTRACTOR

Subcontractors of the vendor are subject to the same requirements as is vendor.

WAVIER OF SUBROGATION

Insurers shall waive all subrogation rights against Beecher and Upper Lakes Public Inland Lake Protection and Rehabilitation District on all policies required under this section.

CANCELLATION NOTICE

Beecher and Upper Lakes Public Inland Lake Protection and Rehabilitation District will be given a 30 day notice in advance of cancellation, non-renewal, or material change in coverage.

PROOF OF INSURANCE

Valid Certificates of Insurance shall be issued to Beecher and Upper Lakes Public Inland Lake Protection and Rehabilitation District prior to the execution of the contract.

XIV. PROJECT CHANGES

Beecher and Upper Lakes Public Inland Lake Protection and Rehabilitation District reserves the right to make changes to the project. Any changes in the scope of services shall be mutually agreed upon in writing by the Vendor and the Beecher and Upper Lakes Public Inland Lake Protection and Rehabilitation District.

XV. ATTACHMENTS

Statement of Qualifications, Attachment A
Fee Schedule, Attachment B
Reference Sheet, Attachment C
Statement of Understanding, Attachment D
Addendum Sheet, if applicable, Attachment E
Sample Contract, Attachment F

ATTACHMENT A
Beecher Lake Dam Modification
Statement of Qualification

All questions shall be answered and the information given shall be clear and comprehensive. If necessary, questions may be answered in the same order on separate attached sheets. Please submit any additional information you feel is pertinent.

1. Company Name (individual, partnership or corporation)

2. Office Address

3. Phone and Fax Numbers

4. How many years have you been engaged in the excavation/construction business under your present company name?

5. Type of work your company presently performs

6. List your experience in projects the same or similar to this project. Please include multiple projects and provide the cost, month and year of project completion.

ATTACHMENT B
Beecher Lake Dam Modification
Fee Schedule

Please identify all costs associated with the item outlined below. Also provide the District with a schedule of labor rates, fees and other expenses that can be used for any unanticipated tasks.

<u>Item</u>	<u>Item Cost</u>
1. Mobilization/Demobilization of Dam Modification Equipment	\$ _____
2. Erosion Control Fencing	\$ _____
3. Clearing and Grubbing	\$ _____
4. Survey Control	\$ _____
5. Schedule 80 PVC Pipe, 10 Inch Diameter	\$ _____
6. Excavate Backfill for Pipe	\$ _____
7. Purchase and Install Seepage Collar with Clay Backfill	\$ _____
8. Purchase and Install Butterfly Valve w/Gear in Dam	\$ _____
9. Purchase and Install Gate Valve	\$ _____
10. Construct Inlet Structure w/Filter Fabric and Rip Rap	\$ _____
	Total Cost \$ _____

The undersigned hereby certifies that they have the knowledge, staffing and expertise necessary to complete the above identified tasks in accordance with the State Statues and Administrative Codes of the State of Wisconsin.

Dated this _____ day of _____, 2015

Name (Individual, Partnership or Corporation)

By: _____
Signature/Title

ATTACHMENT C
Beecher Lake Dam Modification
Reference Data Sheet

(Use of this form is required when submitting proposal)

Provide a list of at least 2 and not greater than 3 customer references with at least one public sector customer.

Agency: _____

Address: _____

Telephone: _____

Contact Person: _____

Agency: _____

Address: _____

Telephone: _____

Contact Person: _____

Agency: _____

Address: _____

Telephone: _____

Contact Person: _____

ATTACHMENT D
Beecher Lake Dam Modification
Statement of Understanding of Proposal

Vendor name

Vendor's address

City State Zip code

Contact person's name & position

Vendor's Phone number Vendor's Fax Number

We have read the District's Request for Proposals (RFP) for Beecher Lake Channel Dredging and fully understand its intent. We certify that we have adequate personnel and equipment to perform said services. We understand our ability and fitness to perform shall be judged solely by Beecher and Upper Lakes Public Inland Lake Protection and Rehabilitation District. In addition, we certify that:

- (a) Our proposal is not made in the interest or on behalf of any person not named therein;
- (b) We have not directly or indirectly induced or solicited any person to submit a false or misleading proposal or to refrain from proposing;
- (c) We have not in any manner sought by collusion to secure an advantage over any other vendor;
- (d) We have thoroughly examined the RFP requirements, and our proposed fees cover all costs for service/equipment we have proposed; and
- (e) We acknowledge and accept all the terms and conditions included in the RFP

Signature of vendor or vendor's Representative

Date

ATTACHMENT E
Beecher Lake Dam Modification
Addendum Sheet

(If Addendums exist for this project, please sign, date, and submit with Proposal.)

The undersigned acknowledges receipt of the following addenda:

Addendum #1 _____ Initials _____

Addendum #2 _____ Initials _____

Addendum #3 _____ Initials _____

Addendum #4 _____ Initials _____

Addendum #5 _____ Initials _____

The undersigned agrees with the following statement:

I have examined and carefully prepared the response to proposal from the plans and specifications and have checked the same in detail before submitting to Beecher and Upper Lakes Public Inland Lake Protection and Rehabilitation District.

Name _____

Signature

Date _____

All vendors are responsible to check for addenda, posted on the county website at www.marinettecounty.com, for this project prior to the due date. No notification will be sent if addenda are posted unless there is an addendum within three (3) business days of RFP due date.

All vendors receiving initial notification of project will be notified by Beecher and Upper Lakes Public Inland Lake Protection and Rehabilitation District of all addenda issued within three (3) business days prior to due date. If a RFP has already been submitted, vendor is required to acknowledge receipt of addendum via fax or e-mail prior to due date. A new RFP response must be submitted by vendor if addendum affects costs.

Vendors that do not have internet access are responsible to contact Marinette County Land Information Office at 715-732-7780 to ensure receipt of addenda issued. RFPs that do not acknowledge addendums may be rejected.

All RFPs submitted shall be sealed. Envelopes are to be clearly marked with required information. Sealed RFPs that are opened by mistake due to inadequate markings on the outside may be rejected and returned to the vendor.

ATTACHMENT F
Beecher Lake Dam Modification
BEECHER AND UPPER LAKES PUBLIC INLAND LAKE PROTECTION AND REHABILITATION
DISTRICT SAMPLE AGREEMENT

THIS AGREEMENT is made by and between Beecher and Upper Lakes Public Inland Lake Protection and Rehabilitation District, a municipality, hereinafter referred to as DISTRICT, and _____, hereinafter referred to as VENDOR, for the purpose of _____.

The parties agree as follows:

1. Contact Persons and Contract Administrators:

DISTRICT's agent and contact person is: Name
Whose principal business address is: Address
Marinette WI 54143

VENDOR agent and contact person is:

Name:
Title:
Company:
Address:
City, State:
Telephone:

2. VENDOR agrees the following services, as set forth in the response to the Request for Proposal (RFP) dated _____ will be provided to Beecher and Upper Lakes Public Inland Lake Protection and Rehabilitation District.
3. VENDOR agrees to present manufacturer's literature regarding materials & warranty.
4. Start/Completion dates to be determined.
5. DISTRICT agrees to the following payment terms:
- DISTRICT will pay the VENDOR 90% of dredging costs within 30 days of receipt of an invoice after dredging is complete.
 - DISTRICT will pay the VENDOR the balance within 30 days of receipt of an invoice after final stabilization and reclamation of disturbed shoreline areas.
6. Both parties agree that the relationship between the parties shall be that of an independent VENDOR and shall not be construed to be an Employer-Employee relationship; specifically the parties agree that:
- VENDOR will be responsible to pay all Federal, State and social security taxes on any income received under this Agreement.

- DISTRICT will pay no fringe benefits or other compensation to VENDOR.

7. VENDOR will provide and maintain certificates of insurance with minimum limits as follows:

General liability, each occurrence	\$1,000,000
Auto liability, each occurrence	\$ 300,000
Workers Compensation	Statutory Requirements

Certificates of insurance indicating DISTRICT as additional insured must be presented to DISTRICT’s agent with a signed copy of this agreement prior to commencing work. Additionally, all policies shall contain endorsements by respective insurance companies waiving all rights of subrogation, if any, against DISTRICT and shall further provide that policies are not cancelable except upon thirty days written notice to DISTRICT.

8. VENDOR hereby agrees to release, indemnify, defend and hold harmless Beecher and Upper Lakes Public Inland Lake Protection and Rehabilitation District, its officials, officers, employees and agents from and against all judgments, damages, penalties, losses, costs, claims, expenses, suits, demands, debts, actions and/or causes of action of any type or nature whatsoever, including actual and reasonable attorney fees, which may be sustained or to which they may be exposed, directly or indirectly, by reason of personal injury, death, property damage, or other liability, alleged or proven, resulting from or arising out of the performance under this agreement by vendor, its officers, officials, employees, agent or assigns. Beecher and Upper Lakes Public Inland Lake Protection and Rehabilitation District does not waive, and specifically reserves, its right to assert any and all affirmative defenses and limitations of liability as specifically set forth in Wisconsin Statutes, Chapter 893 and related statutes.
9. This contract may be amended in writing by mutual agreement of both parties at any time.
10. This agreement shall be governed by the laws of the State of Wisconsin.
11. DISTRICT may terminate this agreement in the event VENDOR breaches any of the terms of the agreement or for unsatisfactory performance by VENDOR. Termination shall be immediate upon written notification by the DISTRICT.

VENDOR

Date

Signature of District’s Representative

Date

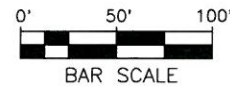

WISCONSIN
 James Brian HUTCHISON
 E-22484
 Green Bay, Wis.
 PROFESSIONAL ENGINEER
 7-10-15

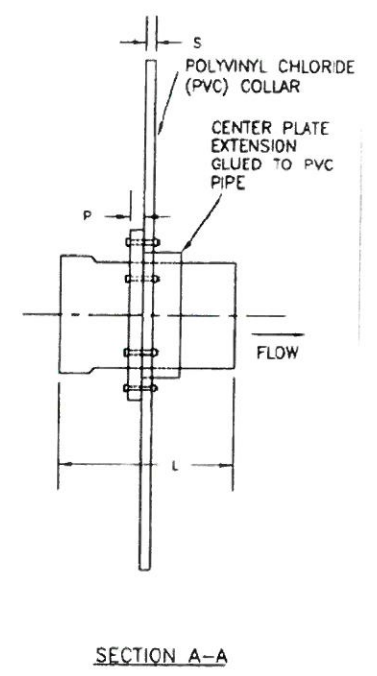
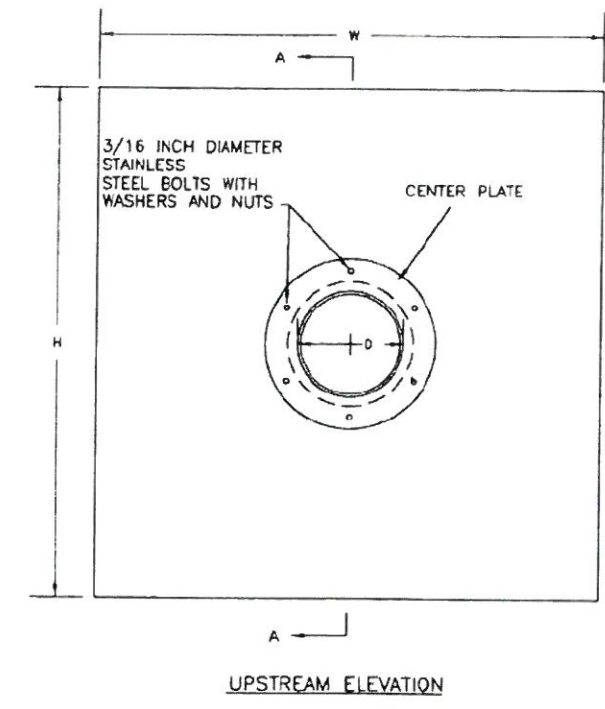

UPSTREAM ELEVATION

SECTION A-A

PIPE DIAM. (D) (INCHES)	SHEET HEIGHT (H) (INCHES)	SHEET WIDTH (W) (INCHES)	SHEET THICKNESS (S) (INCHES)	PIPE LENGTH (L) (INCHES)	PLATE THICKNESS (P) (INCHES)
6	48	48	3/16	12	1/4
8	48	48	3/16	15	1/4
10	48	48	1/4	17	1/4
12	48	48	1/4	17	1/4

- NOTES:
1. THE BELL END OF THE PVC PIPE IN THE COLLAR SHALL POINT UPSTREAM
 2. MAKE PIPE CONNECTIONS AS NEEDED TO ASSURE A WATERTIGHT SYSTEM.
 3. APPLY SILICON CAULK ON THE SEAMS AS NEEDED TO NSURE A GOOD SEAL SO THAT THE COMPLETED INSTALLATION IS WATERTIGHT.

ANTI-SEEP COLLAR TYPICAL DETAIL

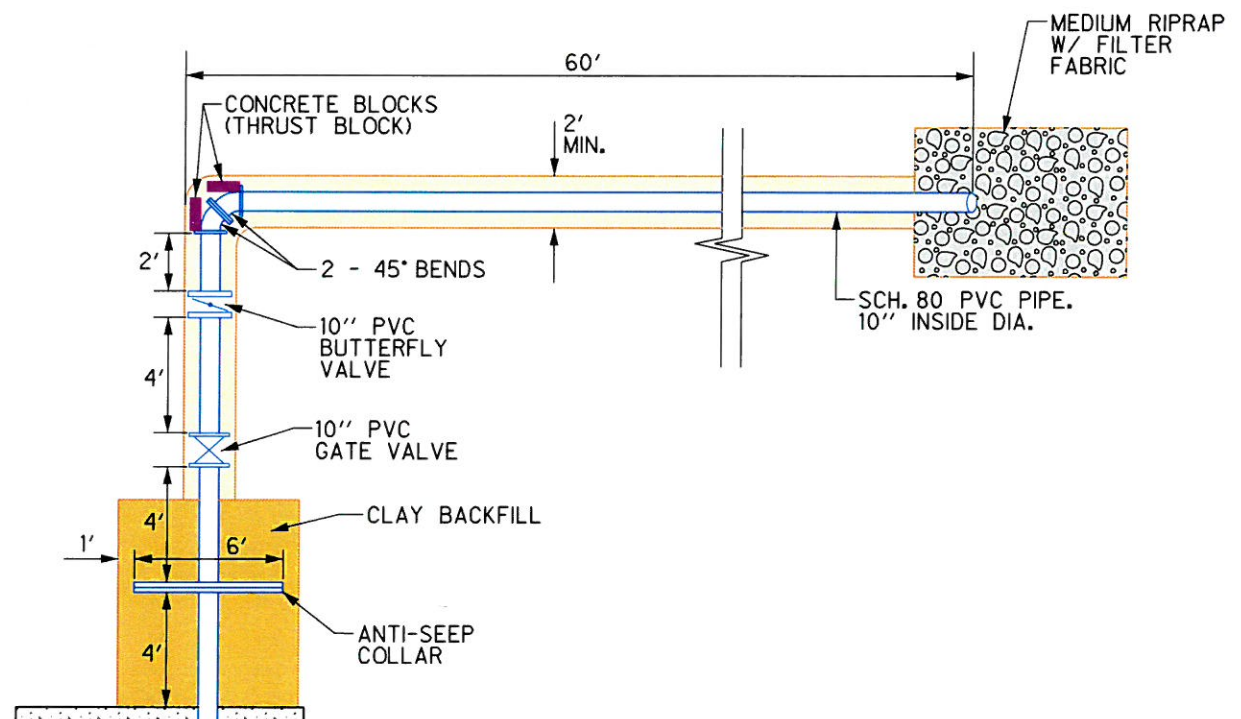

PLAN VIEW

NOTE:
 RAIL GUARD PROTECTION WILL BE INSTALLED ON EACH END OF THE PIPE:
 - TRASH GUARD AT INLET.
 - ANIMAL GUARD AT OUTLET.

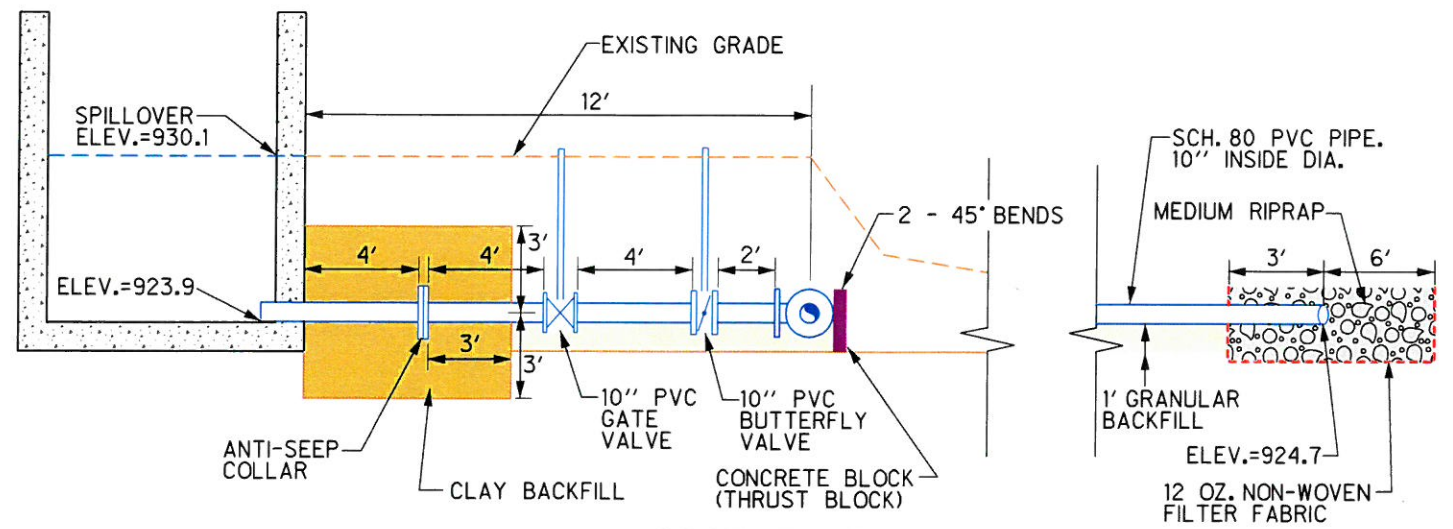

PROFILE VIEW

NOTE: SLOPE OF PIPE IS 1.0%



UNIT PRICE BID

Item No.	Description	Unit	Estimated Quantity
1	Mobilization/Demobilization	LS	1
2	Erosion Control Fencing	LF	300
3	Clearing and Grubbing	acres	0.2
4	Survey Control	LS	1
5	Sched 80 PVC Pipe, 10" Diam	LF	60
6	Excavate/Backfill for pipe	LF	60
7	Purchase and Install Seepage Collar with Clay Backfill	LS	1
8	Purchase and Install Butterfly Valve w/Gear In Dam	LS	1
9	Purchase and Install Gate Valve	LS	1
10	Construct Inlet Structure w/Filter Fabris and Rip Rap	LS	1

BEECHER AND UPPER LAKES EWM CONTROL PROJECT DAM MODIFICATION (DRAIN AND VALVES)

